



Thermal Flow Sensors TA with thin-film sensor element

Probes · Probe guides · Measuring tubes



Examples of Application

Flow measurements also in hazardous locations **Ex** zone 0 or zone 1

- in clean rooms
- in air conditioning and ventilating systems
- for the determination of compressed air consumption
- of activated sludge air in sewage treatment plants
- in outgoing air and exhaust gases
- in deposit gas, argon, helium, CO₂, natural gas, nitrogen, SF₆, methane ...

Specifications
Designs
Information for the user



The principle of Measurement

is based on heat transport from an electrically heated body in ambient medium dependent on the relative velocity between both.

Höntzsch thermal flow sensors TA designed as TA10 probes and measuring tubes TA·Di... use a thin-film sensor element. Thin-film sensor elements consist of an electrically heated Ni-resistor and a Ni-resistor temperature probe. The medium temperature and the temperature difference Dt between the heated Ni-resistor and the medium are the dimensions for the flow.

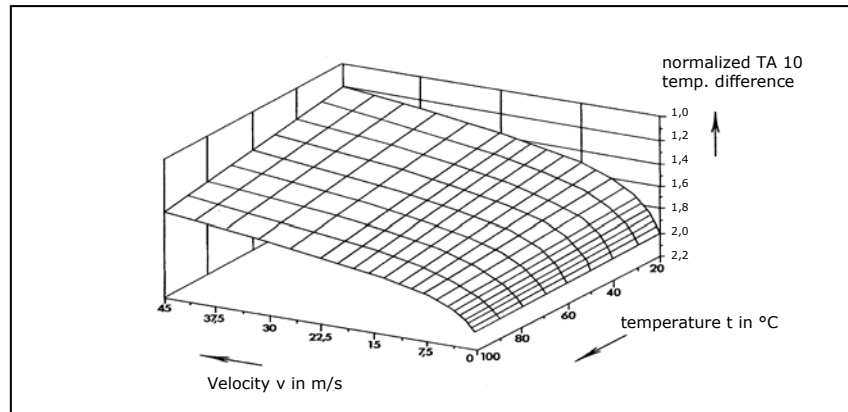

Temperature difference Dt dependent on the standard flow velocity Nv and the temperature t

Thermal flow sensors TA with a thin-film sensor element from Höntzsch are able to measure not only the lowest but also high velocities and meet all requirements for industrial application:

- chemical corrosion resistance
- wide measuring range
- small dimensions of the probes TA10

The T_{95} time constant of the thinfilm sensor element at standard air velocities of around 5 m/s is approx. 1 s.

The diagram shows that the correspondence between temperature difference Dt and the standard flow velocity is also temperature-dependent. Höntzsch flow evaluation units compensate this dependency over the entire temperature application range provided for one sensor respectively.

A characteristic feature to be emphasized when measuring with thermal flow sensors is that the measurement accuracy increases in decreasing flow velocities. In contrast to this, the measurement accuracy increases in increasing flow velocities in the case of vane wheel and vortex flow sensors.

Measurable variable

is the standard flow velocity Nv . The standard volume flow and mass flow can be determined with Nv independent of pressure and temperature.

Standard flow velocity and actual flow velocity

The standard velocity Nv is the velocity at which a gas moves when gas temperature and gas pressure are identical with the standard conditions. The actual flow velocity Bv is the velocity at which a microscopically small particle floats in a flowing medium.

Thermal anemometers measure the standard velocity Nv , that is a velocity which is referred to so-called standard conditions. Measuring the standard velocity with a thermal flow sensor is independent of pressure and temperature.

The standard conditions for Höntzsch are +21 °C (+70 °F) and 1014 hPa (14.7 psia).

The decision whether to apply the standard or actual velocities depends entirely on the measurement requirements.

The standard velocity can be converted to an actual velocity and vice versa using the universal gas equation.

Measuring uncertainty

The measuring uncertainty for probes TA10 is specified at standard velocity measurements of up to 40 m/s with $\pm 2\%$ of the measured value plus ± 0.02 m/s and at standard velocity measurements between 40 m/s and 120 m/s with $\pm 2.5\%$ of the measured value.



Designs of probes TA10

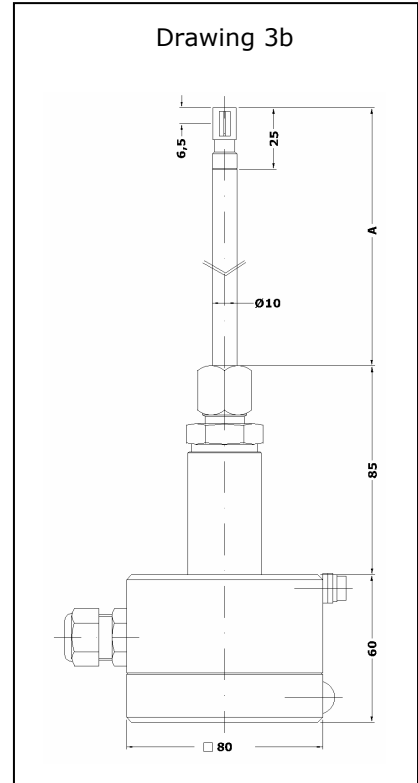
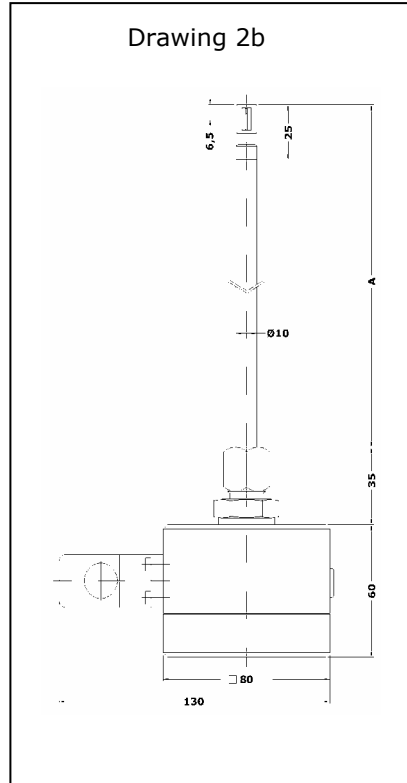
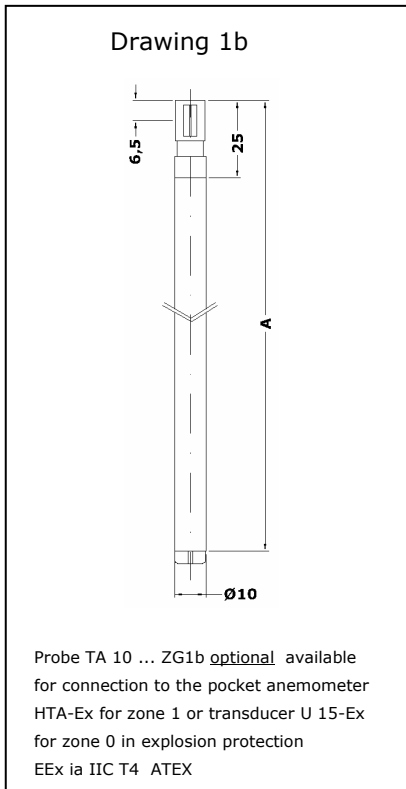

Probes **TA10 ... ZG1b** with connection cable are suitable for connection to the pocket anemometers HTA or HTA-**Ex** or the separate transducers U10a or U15-Ex.

The connection cable of the probe TA10 ... ZG1b has a direct outlet, a standard length of 3 m and a continuous working temperature of max. +140 °C. Connection plug: 423-5 respectively 423-8 if in Ex-execution. The SILICONE-coated cable is protected by an overall shielding for reasons of electromagnetic interference.

Probes **TA10 ... ZG2b** with integrated transducer U10a.

Transducers U10a provided with:
Standard: Output 4-20 mA, pulse output for quantity measurement, RS232-Interface: only for transducer configuration using a PC.
Option with LCD display and resettable quantity counter in the lid of the U10a housing AS80.

Probes **TA10 ... ZG3b Ex** zone 1 with integrated transducer U12-Ex. They are meant for use in locations in which it can be expected that occasionally a hazardous atmosphere arises with explosibility. Explosion protection: **EEx e q [ia] IIC T5 ATEX.**

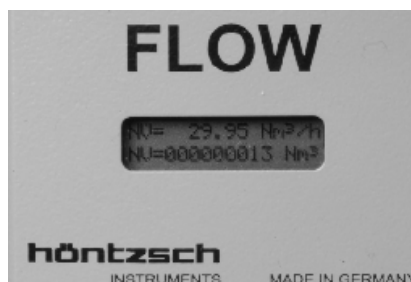

Transducers U12-Ex provided with: Output 4-20 mA, pulse output for quantity measurement, RS232-Interface: only for transducer configuration using a PC. Connection cable: standard length 2 m.

Please note

Do not shorten or lengthen the TA10 ... ZG1b connection cable!

U232_TA_D_e_060324

LCD display with quantity counter

<http://www.hoentzsch.com>



Designs of measuring tubes TA·Di...

Measuring tubes in different designs for direct, stationary installation in pipelines, irrespective of position. Tube connection by pipe fitting (thread in conformity with DIN 2999 = ISO 7, part 1 and 2), cutting ring fitting, etc.

Maximum working pressure up to: 15 bar/1.5 Mpa above atmospheric

Working temperature range: -10 °C ... +140 °

Measuring tubes **TA·Di ... ZG1b** with integrated transducer U10a:

Transducers U10a provided with:
Standard:
 Output 4-20 mA, pulse output for quantity measurement, RS232-Interface: only for transducer configuration using a PC.
Option with LCD display and resettable quantity counter in the lid of the U10a housing AS80.



Measuring tubes TA·Di ... ZG1b with integrated transducer U10a

The measuring tubes **TA·Di ... ZG2b** has a connection cable with direct outlet and are suitable for connection to the pocket anemometer HTA or the separate transducer U10a. The measuring tubes TA·Di ... ZG2b are optional available for connection to the pocket anemometer HTA-Ex (for zone 1) or the transducer U15-Ex (for zone 0) in explosion protection **EEx ia IIC T4 ATEX**

The measuring tubes **TA10 ... ZG5b Ex** zone 1 with integrated transducer U12-Ex. They are meant for use in locations in which it can be expected that occasionally a hazardous atmosphere arises with explosibility. Explosion protection: **EEx e q [ia] IIC T5 ATEX.**

Transducers U12-Ex as described at probes TA10 ... ZG3b.

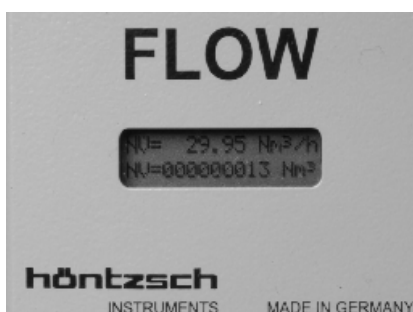

LCD display with quantity counter 4/6

Inside diameter Ø [mm]	Rating standard volume flow [Nm³/h]		Pipe connection SRV = cutting ring fitting	In- stallation length [mm]
	0,2-60 m/s	0,2-120 m/s		
8	0,04- 11	0,04- 22	SRV for pipe 12·2	80 + SRV
16	0,15- 43	0,15- 86	Pipe thread R ½"	320
21,6	0,27- 79	0,27- 158	Pipe thread R ¾"	650
27,2	0,42- 125	0,42- 250	Pipe thread R1"	820
35,9	0,73- 219	0,73- 438	Pipe thread R 1¼"	1080
41,8	1- 296	1- 592	Pipe thread R 1½"	1250



Model designations

Sensor element

A Höntzsch thin-film flow sensor, polyimide-coated.

Probes TA 10

	TA10-285 G E 30m/s 140p 10 ZG1b
	TA10-265 G E 120m/s 140p 10 ZG2b
	TA10-265 G E 60m/s 140p 10/Ex ZG3b
Sensor, probe diameter in mm	10
Probe length in mm	140
Medium G = air/gases	G
Probe material E = stainless steel ...	E
Maximum adjustable nominal value	30
Working temperature range	10
Working pressure above atmospheric Type of Protection	10/Ex
Design according to drawing ZG ... Drawing, German: Zeichnung	ZG3b

Measuring tubes TA·Di ...

	TA·Di 8 G E 120m/s 60p 15 ZG3b
	TA·Di 16 G E 60m/s 140p 10 ZG1b
	TA·Di 41,8G E 120m/s 140p 10 ZG2b
	TA·Di 27,2G E 120m/s 140p 10/Ex ZG5b
Sensor	10
Meas. tube inside-Ø Di in mm	8
Medium G = air/gases	G
Material E = stainless steel ...	E
Maximum adjustable nominal value	60
Working temperature range	15
Working pressure above atmospheric Type of protection	10/Ex
Design according to drawing ZG... Drawing, German: Zeichnung	ZG5b

Measuring range

The smallest measurable value with standard flow velocity measurements of air is approx. 0.2 m/s, the maximum adjustable terminal value depending on sensor type 30 m/s, 60 m/s, 120 m/s or 150 m/s.

Velocity overload: up to 150 m/s

The fatigue strength for infinite time of the sensor element is independent of the flow conditions within the measuring range.

U232_TA_D_e_060324

Medium

Thermal flow sensors TA with a thin-film sensor element are calibrated with air according to standard. Gases other than air can have varied cooling effects and can therefore influence the measurement of a sensor calibrated with/for air.

Disregarding this, thermal flow sensors are also suitable for measurements in single-phase gaseous flows. Measurements in gas mixtures with air or other gases are affected to such an extent that the heat transfer property of the gas mixture differentiates from the heat transfer property of the air.

Upon request: real gas calibrations for deposit gas, argon, helium, CO₂, natural gas, nitrogen, SF₆, methane ...

The use of TA sensors with a thin-film sensor element in particle-charged flows is permissible as long as the finish of the sensor element does not change and deposits are not allowed to collect on the sensor. Mediums may even contain fibres.

Deposits or abrasions on the sensor element can change the heat transmissions and so influence the measurement. The effect of condensation on the sensor is to be regarded in the same way.

Clean soiled sensor heads!

Drifts resulting from variable humidity of the air at normal atmospheric conditions are covered by our specifications for measuring uncertainty.

Working temperature range

for continuous operation
140 -10 °C ... +140 °C
60 -10 °C ... +60 °C

Sensor materials

materials coming into contact with the medium

E stainless steel 1.4571, 1.4305 epoxy resin, glass

<http://www.hoentzsch.com>

Maximum working pressure, pressure dependence

- p10 sensor is designed for pressures above atmospheric of up to 10 bar/1 MPa
- p15 sensor is designed for pressures above atmospheric of up to 15 bar/1.5 MPa

Measurements with absolute pressure of less than approx. 0.7 bar absolute are no longer covered for by the standard data relevant to measuring uncertainty.

The zero point is influenced by absolute pressures which are distinctly higher than 1014 hPa. In the case of non-compensated pressure dependence the following approximate standard flow velocity values *N_v* arise:

- at 0 m/s and 5065 hPa abs
» 5 bar:
measured value *N_v* » 0.25 m/s instead of 0 m/s.
- at 0 Nm/s, 10130 hPa abs
» 10bar:
measured value *N_v* » 0.50 m/s instead of 0 m/s.

This influence is no longer effective at velocities higher than » 1 Nm/s. The software of the flow evaluation units is equipped with the possibility to set the mean working pressure for the purpose of the best possible compensation of the described pressure dependence (compensation for one pressure stage)

Type of protection

all probes and measuring tubes: completely IP65.

Explosion protection Ex ATEX

Probes and measuring tubes with integrated transducer U12-Ex: **EEx e q [ia] IIC T5**.

Probes and measuring tubes with connection cable for connection to the pocket anemometer HTA-Ex (for zone 1) or the transducer U15-Ex (for zone 0):

EEx ia IIC T4



Probe guide pieces SF

are used for inserting and retracting probes TA10 in and out of pipelines and ducts. The fixing device of the probe tube is to be chosen taking the pressure operating conditions into consideration.

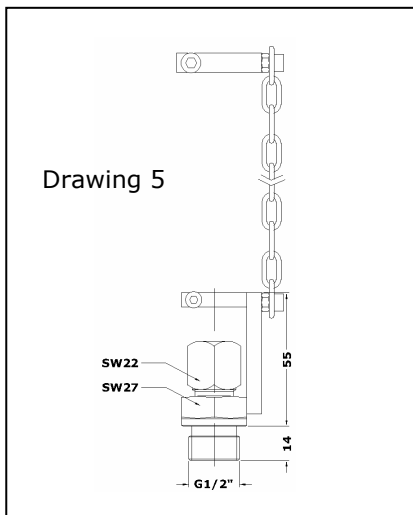
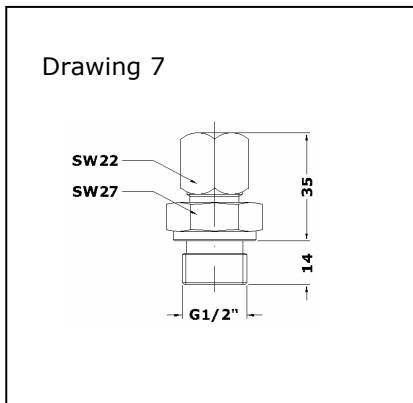

SFB SF design acc. to drawing 5 with clamping bush

SFB SF design as in diagram 7 with clamping bush, clamping device providing extra support for the probe attachment and with or without chain safety device.

Coefficient / Profile Factor PF

PF is used to calculate the local velocity v_p to the average velocity v_m in measurement cross sections:

$$v_m = v_p \cdot PF$$

When measuring with thermal flow probes TA10 in circular measurement cross-sections with interior diameter D_i 25 mm and more then in turbulent flow the following coefficients are to be taken (D_i25 : 0,725; $D_i27,2$: 0,74; $D_i35,9$: 0,79; D_i40 : 0,81; $D_i41,8$: 0,82; D_i50 and more: 0,84) as long as the following conditions are adhered to

- probe to be positioned that the sensor element is centric
- irrotational flow
- developed flow profile, i.e. measurement cross-section so chosen that 20 D_i straight, unhindered input section, amounts to 10 D_i straight, unhindered output section.

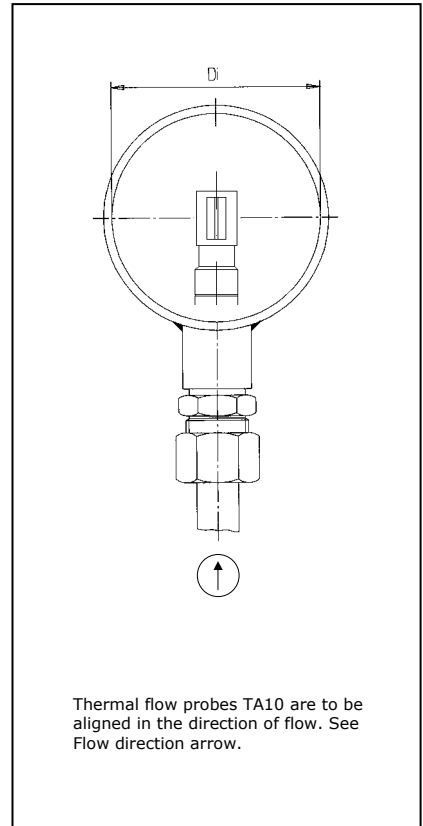

Pressure drop

Pressure drop of several Höntzsch flow probes when measuring in air under normal atmospheric conditions, +20 °C

ZS... Vane Wheel Flow Sensors:
probes with \varnothing 16/25/30 mm
TA... Thermal Flow Sensors:
probes with \varnothing 10/20 mm
VA40 Vortex Flow Sensor

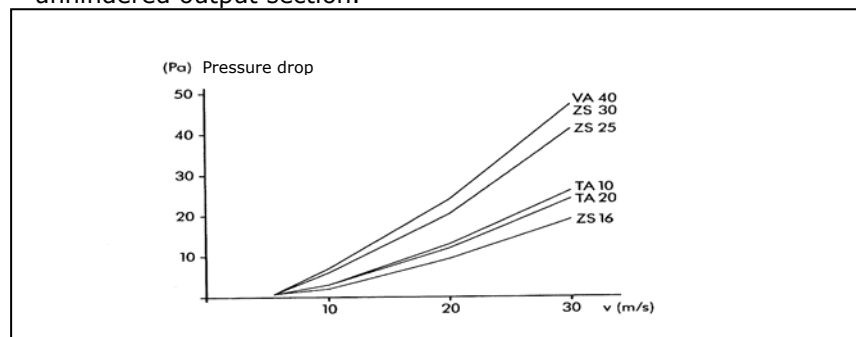

Höntzsch GmbH

P.O. Box 1324 D-71303 Waiblingen
Robert-Bosch-Str. 8
D-71334 Waiblingen (Hegnach)
Telephone 07151/1716-0
Facsimile 07151/58402
E-Mail info@hoentzsch.com
Internet www.hoentzsch.com



FLOWLINE MFG LTD

Elstree Business Centre
Elstree Way, Borehamwood
Herts WD6 1RX
Tel: +44 208 207 6565
Fax: +44 208 207 3082
E-Mail sales@flowline.co.uk
Internet www.flowline.co.uk